

NL-SWDK2 Datasheet

NimbeLink Corp

Updated: November 2020



© NimbeLink Corp. 2020. All rights reserved.

NimbeLink Corp. provides this documentation in support of its products for the internal use of its current and prospective customers. The publication of this document does not create any other right or license in any party to use any content contained in or referred to in this document and any modification or redistribution of this document is not permitted.

While efforts are made to ensure accuracy, typographical and other errors may exist in this document. NimbeLink reserves the right to modify or discontinue its products and to modify this and any other product documentation at any time.

All NimbeLink products are sold subject to its published Terms and Conditions, subject to any separate terms agreed with its customers. No warranty of any type is extended by publication of this documentation, including, but not limited to, implied warranties of merchantability, fitness for a particular purpose and non-infringement.

NimbeLink is a registered trademark, and Skywire is a registered trademark, of NimbeLink Corp. All trademarks, service marks and similar designations referenced in this document are the property of their respective owners.

Table of Contents

Table of Contents	2
Introduction	3
Contact Information	3
Orderable Part Numbers	3
Additional Resources	3
Technical Specifications	4
Overview	4
Electrical Specifications	4
ESD Warning	4
Absolute Maximum and Minimum Ratings	4
Board Connectors	5
Skywire Modem Socket Pinout	5
Arduino Interface Pinout	6
Grove Connector Pinouts	7
Mechanical Characteristics	8
Mechanical Drawing	8
Mechanical Specifications	8
Environmental Specifications	8
Hardware Description	9
Block Diagram	9
Modem Placement	10
Power	10
USB Communication	11
UART Communication	11
UART Selection	12
ON_OFF Control	12
Power On	12
Power Off	13
SW1 DIP Switch	13
User Button	13
User LED	13
Grove Connectors	14
Version Information	15

1. Introduction

This document serves as the hardware datasheet for the Skywire Development Kit Version 2 platform. Throughout this document the Skywire Development Kit Version 2 will be referred to by its abbreviated name, SWDK2, or by its part number, NL-SWDK2.

1.1 Contact Information

NimbeLink's goal is to make integrating Skywire modems into end-user applications as easy as possible. Please send any feedback, documentation requests, or technical support questions to NimbeLink's product support team at:

product.support@nimbelink.com

For purchasing information, please visit the "Part Ordering Information" section on the adapter's product page. Any additional sales questions or requests for quotation can be directed to NimbeLink's sales team at:

sales@nimbelink.com

1.2 Orderable Part Numbers

Orderable Device	Compatible Modems	Operating Temperature
NL-SWDK2	All Skywires*	-40°C to +85°C

*This modem is compatible with all Skywire modems using the standard Skywire interface. This development kit is not compatible with Skywire Nano products.

1.3 Additional Resources

- [Skywire Software Developers Guide](#)
- [Skywire Hardware Developers Guide](#)
- [NL-SWDK2 Product Page](#)
- [NL-SWDK2 Schematic](#)
- [NL-SWDK2 Altium Design Files](#)

2. Technical Specifications

2.1 Overview

The SWDK2 is a versatile standalone and Arduino compatible Skywire Development kit for the Skywire modem that allows for the rapid prototyping of a variety of IOT applications. The kit allows for the easy addition of Skywire modems to Machine to Machine (M2M) systems with an Arduino interface and for using the Skywire by itself over a USB interface with a host PC. This adapter is compatible with all Skywire modems using the standard Skywire interface.

This development kit is designed to allow for the easy evaluation of the Skywire modem in many applications including, but not limited to:

- Telematics platforms
- Asset Tracking
- Industrial Monitoring
- Internet Connectivity
- Agricultural Monitoring
- Smart Cities
- Smart Utilities
- Fleet Management

2.2 Electrical Specifications

2.2.1 ESD Warning

This device is an ESD sensitive device. Proper ESD handling precautions should be used when handling this device.

2.2.2 Absolute Maximum and Minimum Ratings

To avoid potential damage to the modem, ensure that all voltages applied to the development kit listed below do not fall outside of the ranges specified by the maximum and minimum ratings:

Parameter	Pin(s)	Min. Rating	Max. Raing
Main Power Supply Input (J15)	J15-1	5.0V	15V

2.3 Board Connectors

2.3.1 Skywire Modem Socket Pinout

The following table details the pinout of the Skywire modem socket on the development kit.

Pin	Name	Direction	Description	Min	Typ.	Max
1 (J1-1)	VCC	Input	Main Power Supply Pin		4.0V	
2 (J1-2)	DOUT	Output	Not Connected	0V		VREF
3 (J1-3)	DIN	Input	Not Connected	0V		VREF
4 (J1-4)	GND	-	Ground Pin		0V	
5 (J1-5)	nRESET	Input	Modem reset signal	0V		1.8V
6 (J1-6)	VUSB	Input	USB connection detection		5.0V	
7 (J1-7)	USB_P	I/O	USB differential data bus (+)		-	
8 (J1-8)	USB_N	I/O	USB differential data bus (-)		-	
9 (J1-9)	DTR	Input	Data terminal ready. Tied low.	0V		VREF
10 (J1-10)	GND	-	Ground Pin		0V	
11 (J2-1)	GND	-	Ground Pin		0V	
12 (J2-2)	CTS	Output	Modem CTS Pin	0V		VREF
13 (J2-3)	ON/nSLEEP	Output	Modem status pin	0V		1.8V
14 (J2-4)	VREF	Input	Voltage reference for offboard I/O signals	0V		VREF
15 (J2-5)	GND	-	Ground Pin		0V	
16 (J2-6)	RTS	Input	Modem RTS Pin	0V		VREF
17 (J2-7)	GPIO_3	I/O	Modem GPIO pin	0V		1.8V
18 (J2-8)	GPIO_2	I/O	Modem GPIO pin	0V		1.8V
19 (J2-9)	RING/ADC	I/O	Modem ADC or Ring Indicator Pin	0V		1.8V
20 (J2-10)	ON_OFF	Input	Modem ON_OFF Control. Driven by U3.	0V		1.8V

2.3.2 Arduino Interface Pinout

Conn.	Pin	Arduino Name	Dev Kit Assignment	Description
J12	1	D0	UART_RX1	UART RX connection for Arduino interface connected to Skywire modem DOUT pin through onboard MUX.
	2	D1	UART_TX1	UART TX connection for Arduino interface connected to Skywire modem DIN pin through onboard MUX.
	3	D2	UART_RX2	UART RX connection for Arduino interface connected to Skywire modem DOUT pin through onboard MUX.
	4	D3	LED_ORANGE	GPIO control for Orange channel of onboard tricolor LED.
	5	D4	SKY_CTS	Arduino GPIO control for Skywire CTS pin.
	6	D5	SKY_RTS	Arduino GPIO control for Skywire RTS pin.
	7	D6	PWR_nENABLE	Arduino GPIO control for Skywire 4V0 regulator PWR nEnable pin.
	8	D7	SKY_DTR	Arduino GPIO control for Skywire DTR pin.
J10	1	D8	UART_TX2	UART TX connection for Arduino interface connected to Skywire modem DIN pin through onboard MUX.
	2	D9	SKY_RESET	Arduino GPIO control for Skywire Reset Line.
	3	D10	SKY_ADC/RING	Arduino GPIO connection for monitoring Skywire ADC/RING pin.
	4	D11	GROVE_IO3	Arduino GPIO connection to Grove Connector J8.
	5	D12	LED_BLUE/ GROVE_IO4	Arduino GPIO connection to Grove Connector J8 and control pin for blue LED channel on D7.
	6	D13	LED_GREEN	Arduino GPIO control pin for green LED channel on D7.
	7	GND	System Ground	System Ground Pin.
	8	AREF	Arduino Analog Reference	Arduino Analog Reference Pin
	9	I2C_SDA	Arduino I2C SDA	Arduino I2C SDA pin connected to Grove Connector J7 and J9.
	10	I2C_SCL	Arduino I2C SCL	Arduino I2C SCL pin connected to Grove Connector J7 and J9.
J13	6	A0	SKY_ON_OFF_SW	Arduino GPIO connection for controlling modem ON_OFF circuitry.
	5	A1	GROVE_IO1	Arduino GPIO connection to Grove connector J6.
	4	A2	GROVE_IO2	Arduino GPIO connection to Grove connector J6.
	3	A3	SKY_ONSLEEP_VREF	Arduino GPIO connection for monitoring Skywire Pin 13.
	2	A4	SKY_DIO3_VREF	Arduino GPIO connection for monitoring Skywire Pin 17.
	1	A5	SKY_DIO2_VREF	Arduino GPIO connection for monitoring Skywire Pin 18.
J11	1	VCC_VIN	VCC_VIN	System power input. Connected to Skywire power IC U5.
	2	Ground	Ground	System Ground Pin.
	3	Ground	Ground	System Ground Pin.
	4	VCC_ARD_5V0	VCC_ARD_5V0	Arduino interface 5.0V power rail.
	5	VCC_ARD_3V3	VCC_ARD_3V3	Arduino interface 3.3V power rail.
	6	ARD_RESET	ARD_RESET	Arduino interface reset pin.
	7	VCC_ARD_IOREF	VCC_ARD_IOREF	Arduino interface IO reference.
	8	NC	NC	Pin not connected.

2.3.3 Grove Connector Pinouts

The table below contains the pinout for the four grove connectors on the development kit. By default, connectors J6 and J7 are not populated (NP).

Conn.	Pin	Arduino Pin Connection	Dev Kit Assignment	Description
J7 (NP), J9	1	Ground	Ground	System Ground Pin.
	2	Arduino_SDA	Grove_SDA	Grove pin connected to Arduino interface I2C data IO.
	3	Arduino_SCL	Grove_SCL	Grove pin connected to Arduino interface I2C data IO.
	4	VCC_ARD_IOREF (J11-7)	VCC_VREF	Grove Sensor VCC power connected to system reference voltage. Available power is subject to host board limitations.
J6 (NP)	1	Ground	Ground	System Ground Pin.
	2	A2	GROVE_IO2	Grove pin connected to Arduino interface pin A1.
	3	A1	GROVE_IO1	Grove pin connected to Arduino interface pin A1.
	4	VCC_ARD_IOREF (J11-7)	VCC_VREF	Grove Sensor VCC power connected to system reference voltage. Available power is subject to host board limitations.
J8	1	Ground	Ground	System Ground Pin.
	2	D12	GROVE_IO4	Grove pin connected to Arduino interface pin D12.
	3	D11	GROVE_IO3	Grove pin connected to Arduino interface pin D11.
	4	VCC_ARD_IOREF (J11-7)	VCC_VREF	Grove Sensor VCC power connected to system reference voltage. Available power is subject to host board limitations.

2.4 Mechanical Characteristics

2.4.1 Mechanical Drawing

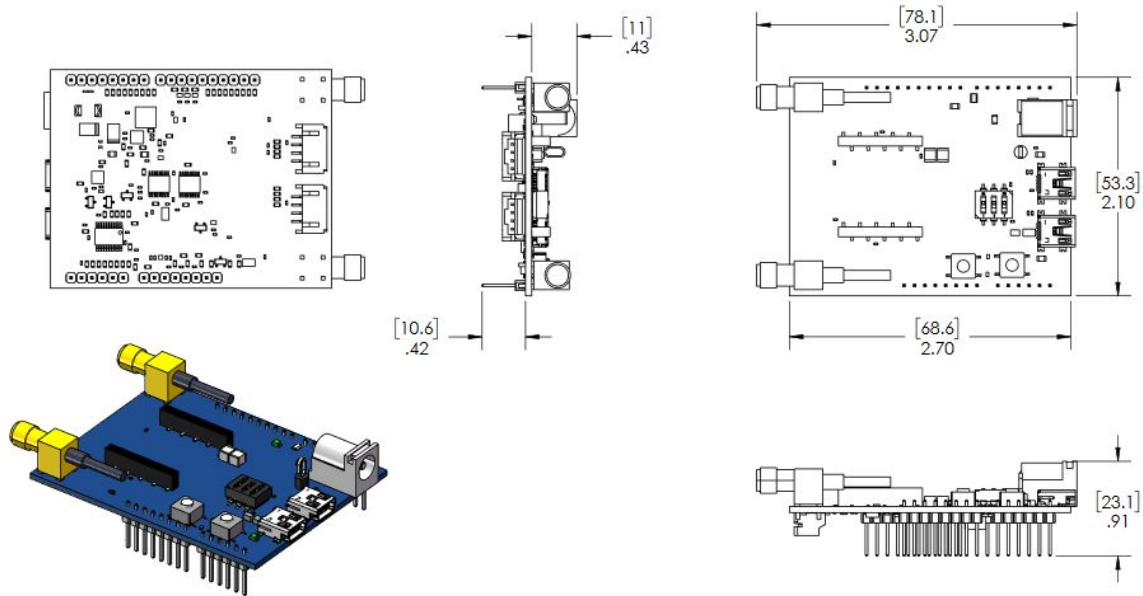

2.4.2 Mechanical Specifications

Parameter	Typical	Unit
Dimensions	78.1 x 53.3 x 23.1	mm
Weight	32	Grams
Connector Insertion/Removal	10	Cycles

2.4.3 Environmental Specifications

Parameter	Min	Typical	Max	Unit	Note
Operating Temperature	-40	+25	+85	°C	
Storage Temperature	-40	+25	+85	°C	
Operating Humidity	20		90	%	Non-condensing

3. Hardware Description

The following is a list of some of the hardware features of the NL-SWDK2:

- 20 Pin Skywire Interface
- Skywire USB and USB to Serial USB interfaces
- Skywire Modem automatic turn on circuitry
- Flexible 5V-15V (12V typical) board power supply input
- Arduino interface
- 2x Grove connectors for Arduino platforms
- 2x PCB Mount u.FI to SMA 50Ω RF connectors
- 1x tricolor LED

3.1 Block Diagram

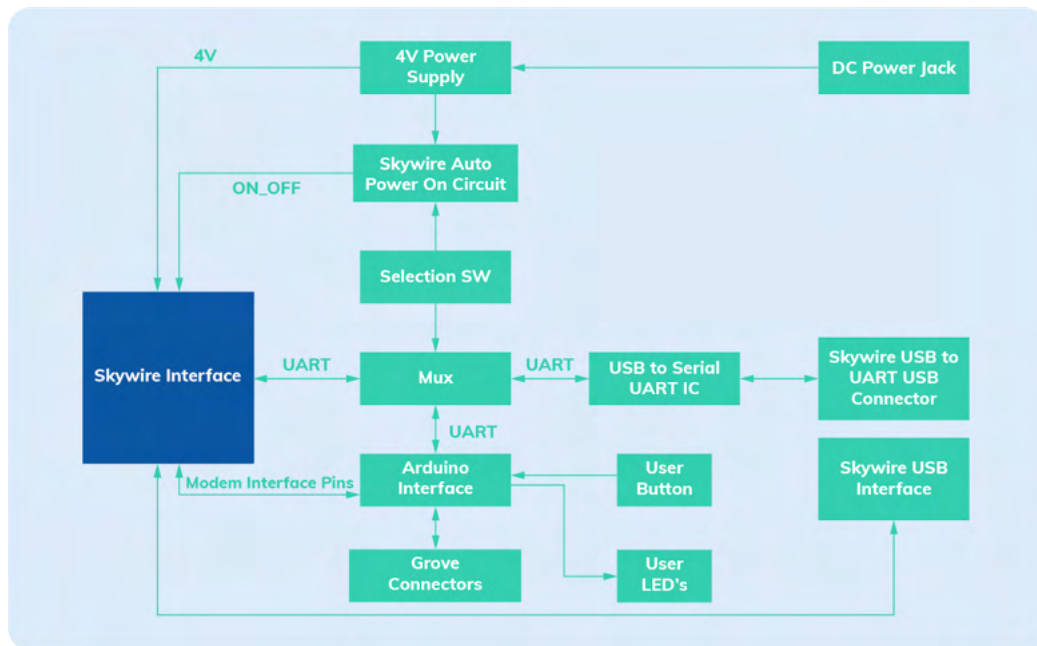

3.2 Modem Placement

⚠ Make sure the Skywire is installed in the correct orientation in your host board. Failure to do so will damage the device and void the warranty.

To seat the modem, align the Skywire modem's u.FI connectors with the two circles seen on the top of the SWDK2's Skywire socket. When viewing the mPCIe adapter from the top, the modem's u.FI connectors should be in the middle of the development kit when mounted. An example photo of the placement is below.



3.3 Power

The SWDK2 development kit may be powered through the 2.1mm barrel jack, J15, or through the VIN pin on the Arduino interface. The power supply connected to the development kit should be able to provide at least 8 watts of power to the SWDK2 plus any additional power required for a connected arduino board or any sensors.

The J11 barrel jack will provide power to the Arduino VIN pin on J11-1 for powering host processor boards.

When the board is powered the green D4 LED will be on.

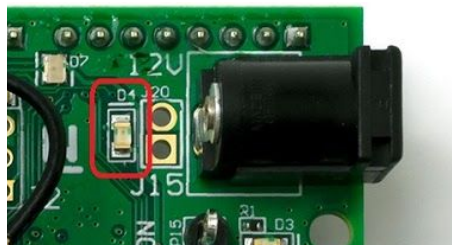

The acceptable input power range for the development kit is shown in the table below.

Parameter	Pin(s)	Min. Rating	Max. Raing
Barrel Jack Power Input (J15)	J15-1	5.0V	15V
Arduino VIN Power Input (J11-1)*	J11-1	5.0V	15V

*The acceptable Arduino header VIN voltage input range will depend on the development kit being used. Consult the Arduino style host boards datasheet to determine the appropriate input voltage for the host processing board.

3.4 USB Communication

The SWDK2 offers a USB 2.0 interface to the Skywire modem on connector J5, which is highlighted below. This interface utilizes a USB-Mini connector. USB drivers for the Skywire modem are available for download on the specific modem's product page.



3.5 UART Communication

The SWDK2 provides a USB to serial UART interface to interface with the Skywire modem's serial UART. This is accessible through connector J14, which is highlighted below. This interface utilizes a USB-Mini connector.



The USB to serial UART IC is an FTDI FT234XD. The FTDI drivers for the FT234XD are available on [FTDI's website](https://www.ftdi.com/).

3.6 UART Selection

The Skywire modem's UART interface is multiplexed to several different interfaces on the development kit to allow for easy interfacing with different host development kits and for accessing it through the USB to serial UART interface (J14). The UART selection multiplexer allows for the UART to be routed to one of the following interfaces:

- USB to Serial interface on J14
- Arduino Interface 1 on Arduino pins D0/D1
- Arduino Interface 2 on Arduino pins D2/D8

The USB to serial interface will be automatically selected when a USB connection is powered on J14 and will override the selection switch for the Arduino interfaces. This feature could be bypassed if desired by modifying the circuit board.

The interface selection for the Arduino interfaces is controlled by the switches on SW1 according to the following logic table:

Interface Selection	SW1-1 Position	SW1-2 Position
Test Points (TP16-TP19)	OFF	OFF
Arduino Interface 1 (D0/D1)	ON	OFF
Arduino Interface 2 (D2/D8)	OFF	ON
USB to Serial Interface	ON	ON

Below is an image of the switch locations on SW1.

3.7 ON_OFF Control

3.7.1 Power On

The development kit can automatically boot the modem when power is applied by turning SW1-3 to the on position. The development kit has a built in automatic turn on circuit using a TI TPL5111DDCR (U1) that will toggle the modem's ON_OFF pin low one time for about 8 seconds after the 4.0V supply is applied. The automatic turn on circuit can be enabled or disabled based using the SW1-3 DIP switch.



3.7.2 Power Off

Prior to removing the development kit's power, the cellular modem must be properly powered down. Removing power prior to shutting down the modem violates carrier standards and may damage the modem. Please see the AT command manual of the modem being used for the proper shutdown command for the modem. Users must wait for the modem to fully de-enumerate from the host system prior to removing power.

3.8 SW1 DIP Switch

The SW1 DIP switch on the development kit is used for controlling the UART multiplexer as described in section 3.6 and for enabling or disabling the auto power on circuit for the modem as described in section 3.7.1. New development kits will have a piece of Kapton tape over SW1, this tape may be removed by the user. Each switch location, SW1-1, SW1-2, and SW1-3, are marked on the DIP switch as 1, 2, and 3, respectively. There is also silkscreen marking for the ON position and for the functionality of each switch.



3.9 User Button

The development kit has one momentary switch user button that is connected to the Arduino interface A1.

3.10 User LED

The development kit has one tricolor green-blue-orange LED that is connected to the Arduino interface. Each LED channel is controlled by an N-Channel Mosfet and the connection pinout is shown in the table below.

LED Color	Arduino Control Pin
Orange	D3
Blue	D12
Green	D13

3.11 Grove Connectors

The development kit has footprints for up to four grove connectors, however only the connectors on the back side of the board, J8/J9, are populated. J6/J7 are not populated and may have some mechanical clearance issues with some Skywire modems. The pinout for the grove connectors is available in section 2.2.3.

4. Version Information

Revision	Notes	Date
1	-Initial Release	2020/11/11